

TECHNICAL FEATURES

50 Hz L = 8 bar H = 10 bar HH = 13 bar - 60 Hz LX = 8 bar HX = 10 bar

Model ERC	Rated motor power kW	Free Air Delivery*					Sound pressure level**		Receiver PACKAGE ERCS - ERCSE
		m ³ /min					dB(A)		
		L	H	HH	LX	HX	50 Hz	60 Hz	
504	4	0,7	0,53	0,49	0,73	0,63	71	73	270
505	5,5	0,89	0,76	0,57	1,02	0,82	71	73	270
507	7,5	1,38	1,15	0,96	1,39	1,2	75	77	270
511	11	1,97	1,7	1,35	2,11	1,87	75	77	270
1015	15	2,7	2,2	1,87	3,01	2,65	79	81	-
1018	18,5	3,28	2,64	2,26	3,67	3,18	79	81	-
1022	22	3,75	3,2	2,57	3,95	3,6	79	81	-

Working pressures: 7,5 bar for 8 bar version - 9,5 bar for 10 bar version - 12,5 bar for 13 bar version

(*) Free air delivery as per ISO 1217: 1996 annex "C"

(**) Sound pressure level as per PN8NTC2.3, value measured at 1 m distance

DIMENSIONS (mm) - WEIGHTS (kg)

	A	B	C	Weight (kg)
ERC				
504 - 505	960	430	650	110 - 115
507	1180	480	760	170
511	1180	480	760	180
1015 - 1018	1450	550	890	305
1022	1450	600	890	310

	A	B	C	Weight (kg)
ERCS				
504	1640	580	1230	200
505	1640	580	1230	205
507	1640	600	1330	265
511	1640	600	1330	275

	A	B	C	Weight (kg)
ERCSE				
504	1640	600	1260	230
505	1640	600	1260	240
507	1850	650	1360	305
511	2050	690	1450	360

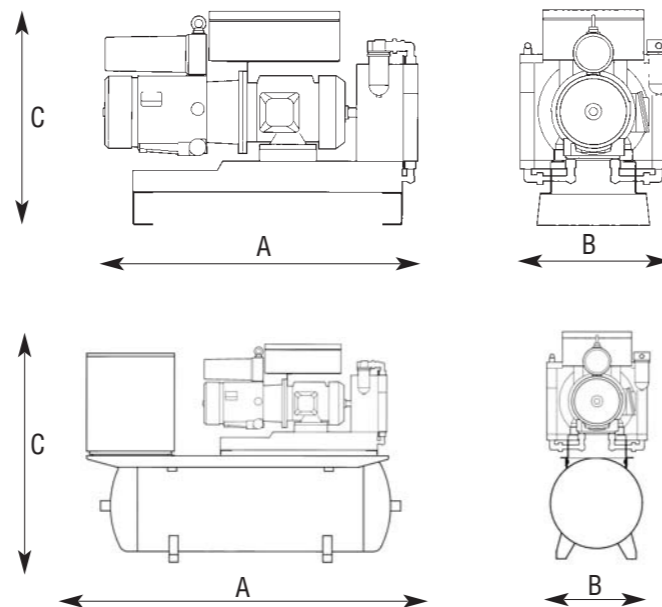

Ing. Enea Mattei SpA reserves the right to change the data contained in this catalogue at any moment and without notice.

ITALY

ING. ENEA MATTEI SpA
Strada Padana Superiore, 307
20090 VIMODRONE (MI)
Tel +39 02253051 - Fax +39 0225305243
E-MAIL: info@mattei.it

FRANCE

MATTEI COMPRESSEURS Sarl
Phone +33 1 60081212 - Fax +33 1 60085252
E-MAIL: info@mattei.fr

GERMANY

MATTEI KOMPRESSOREN DEUTSCHLAND GmbH
Phone +49 7151 5002560 - Fax +49 7151 5002565
E-MAIL: info@mattei-kompressoren.de

GREAT BRITAIN

MATTEI COMPRESSORS Ltd
Phone +44 (0)1789 450577 - Fax +44 (0)1789 450698
E-MAIL: info@mattei.co.uk

RUSSIAN FEDERATION

ING. ENEA MATTEI SpA
Phone +7-495-739 41 90 Fax +7-495-739 41 90
E-MAIL: mattei@inbox.ru

SINGAPORE Representative Office Asia Pacific

ING. ENEA MATTEI SpA
Phone +65 6741 8187 - Fax +65 6741 6826
E-MAIL: mattei@singnet.com.sg

U.S.A.

MATTEI COMPRESSORS Inc
Phone +1 410 5217020 - Fax +1 410 5217024
E-MAIL: info@matteicomp.com

www.mattei.it



COMPANY
WITH QUALITY MANAGEMENT
SYSTEM CERTIFIED BY DNV
= ISO 9001 : 2000 =



500 - 1000

ERC Series



Compact-Versatile-Silent Running

ERC

Mattei's rotary vane compressors of the 500-1000 series, with installed powers from 4 to 22 kW, are the ideal solution for small/medium industry compressed air needs. Available in ERC version, they come complete with automatic flow rate control at constant pressure, aftercooler and electronic condensate drain. The machines have an extremely compact design, are easy to install and offer a reliable operation and constant performance through time.

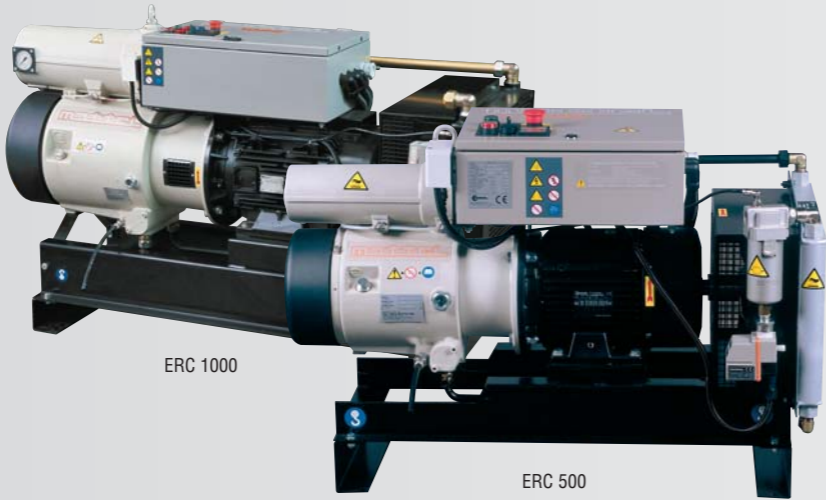

PACKAGE

Mattei PACKAGE compressors, with installed powers from 4 to 11 kW, are complete and ready to use compressed air centres. These silent and reliable compressors are available in different versions; ERCS: the compressor is installed on a horizontal receiver. ERCSE: the compressor is connected to a refrigerant thermal mass dryer and installed on a receiver. This installation provides quality air without oil and water (Pressure dew point +3°C).

TECHNOLOGY

OPERATION PRINCIPLE

The air is sucked through a filter and passes through a modulating proportional valve which regulates air delivery according to air requirement. This valve allows to maintain a constant working pressure. The air goes into the compression chamber where the stator, rotor and blades create a series of vanes (or volumes). The rotor rotates eccentrically to the stator and is characterised by vertical slots in which the blades are placed and are pushed against the stator's wall by centrifugal force. Lubrication and cooling are guaranteed by an efficient injection system which allows perfect hold and a lower lubricant consumption. A thin film of oil on the stator's wall avoids direct contact of the metal parts giving no wear.

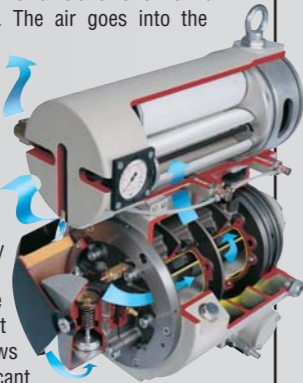

ENERGY CONSUMPTION

Thanks to the meticulous design, the compressor has one of the lowest energy consumption per cubic metre of delivered air rates. The regulation system, allowing to choose between continuous or automatic with off-load operation, is standard on each machine and allows to adapt operation to the needs of the customer.

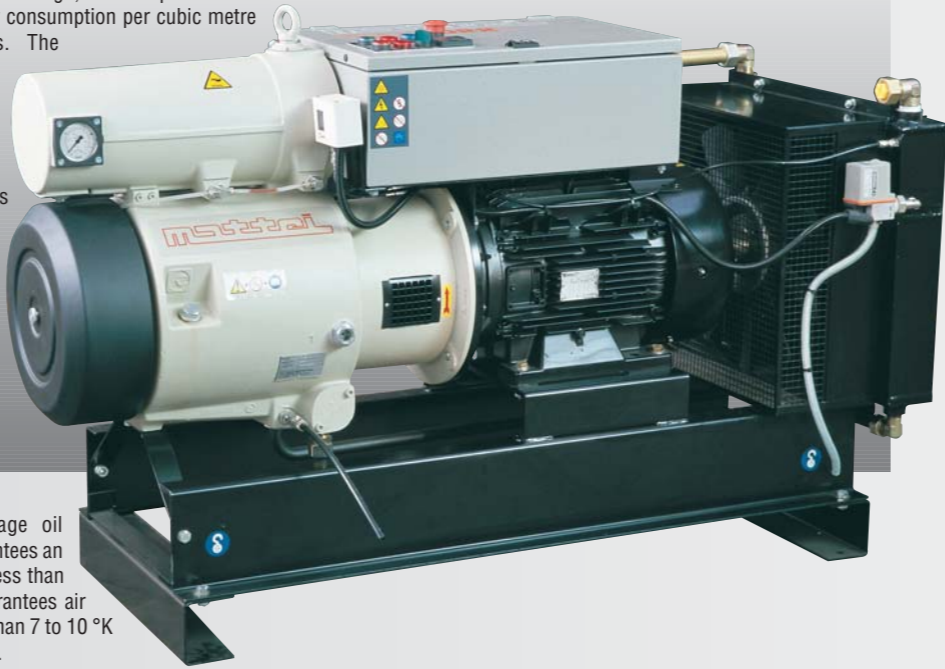

AIR QUALITY

The exclusive three-stage oil separating system guarantees an oil carry-over in the air less than 3 ppm. The coolers guarantees air temperatures no higher than 7 to 10 °K above room temperature.

ENERGY SAVING REFRIGERANT DRYERS

Water vapour in compressed air systems will cause the following problems: piping corrosion, wear of pneumatic equipment, hydraulic leak of pneumatic cylinders. These can result in: lost production, uncontrollable manufacturing costs. ERCSE compressors with Mattei Dryer avoid these effects.



CONTROL PANEL

The control panel is simple and functional: it includes an hour-meter, on and off buttons, the selection for automatic or continuous operation, and the emergency stop button. It is also equipped with different automatic safety devices and is predisposed for remote control connection.



CONDENSATE SEPARATOR

Each Mattei compressor is equipped with an air cooler and a separator with an electronic condensate drain.



AIR/OIL SEPARATION

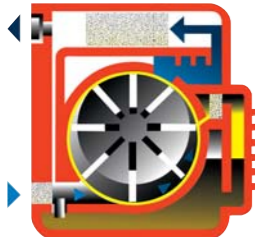

The three-stage system for separating the oil from the air assures the oil residue level in the compressed air remains lower than 3 ppm. This system offers low oil consumption and a longer lifetime of the coalescence air/oil separation filters.

NO MAINTENANCE (THERE ARE NO BEARINGS)



Unlike other compressors, the absence of axial thrust in the Mattei vane compressors eliminates the need for rotating bearings. This allows Mattei compressors to enjoy very long and inexpensive maintenance intervals.

DIRECT COUPLING

A flexible joint between the motor and the compressor ensures perfect alignment, silent running, slow speed (just 1500 rpm), no power loss and no maintenance.



AUTOMATIC FLOW CONTROL

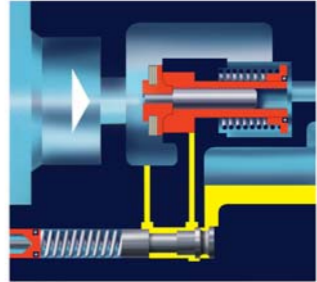

The special proportioning and modulating intake valve fitted to Mattei compressors allows the compressor to work without a receiver: when the maximum required pressure is reached, the intake valve closes to reduce the quantity of intake air, thus keeping pressure constant. As the line pressure reduces, the valve automatically opens to keep pressure constant.